



TECHNICAL DATASHEET

BM 401

CONTACT US:

1 Grande rue
54540 MONTIGNY, France
Tel: +33 3 83 42 15 79



WWW.PLAISANCE-EQUIPEMENTS.COM

BM 401

GENERAL INFORMATION

Rotor widths	1,2 m	1,3 m	1,5 m
Rotor diameter	500 mm		
Use	Stone crushers		
Teeth	Single carbide tip		
Teeth position on the rotor	Fixed - Helical and V positions		
Working depth	- 50 mm		
Engine power	70 to 120 hp		
Side belt transmission to rotor	4 V-belts		
Curtain of chains	Anti-projection curtain of chains		
Protection door	Hydraulic with two cylinders (public works)		
Frame	Strengthen - High tensile steel and HARDOX®		
Rollings	Heavy duty roller bearings with double rows of rollers		
Rotor axis	Bolted shafts		
Skids	HARDOX 450® soles		
Protections	Anti-wire cut in mass, bolted and interchangeable		
Gearbox	300 hp		
Hitch	2 nd hydraulic point		

HOLDERS

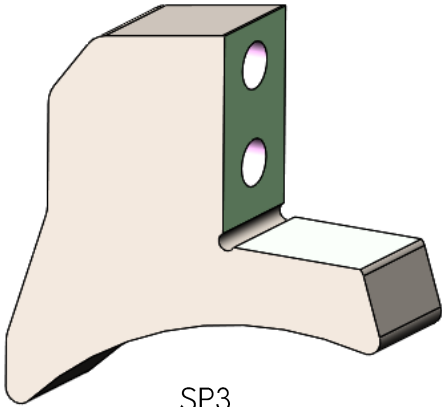

SP3

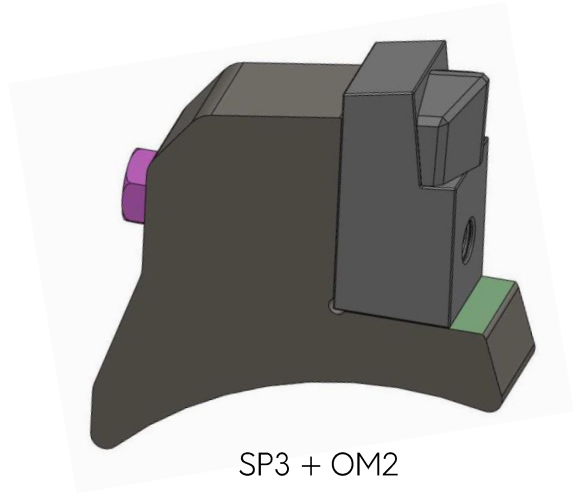

SP3 + OM2

TEETH



Stone tool
Single carb tip

OM2
30 to 40 teeth

THE **STRENGTHS** OF OUR MULCHERS



Saving time: continuous hydraulic setting of the working depth from the cab thanks to the 3rd hydraulic point.



Profitability: high work flow and low cost of wear parts.



Exceptional mixing quality: the helical teeth ensures a homogeneous mix, reducing power demand and increasing fertility.



Heavy-duty design inspired by Publics Works thanks to the use of high-quality materials.



Simplicity and reliability of the kinematics (with few maintenance) allows a profitability gain.



Design in the rules of mechanics



Fuel-efficient due to low drawbar pull



Cost of use per hectare below all competitors

PLAN AND DIMENSIONS

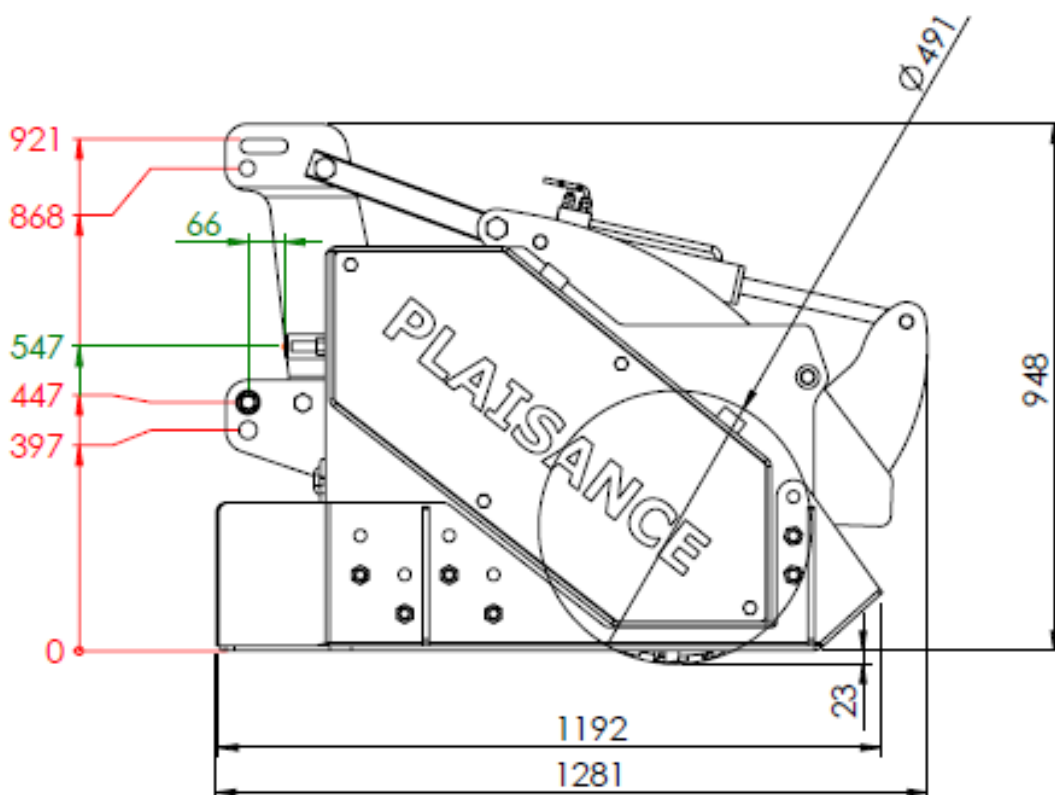
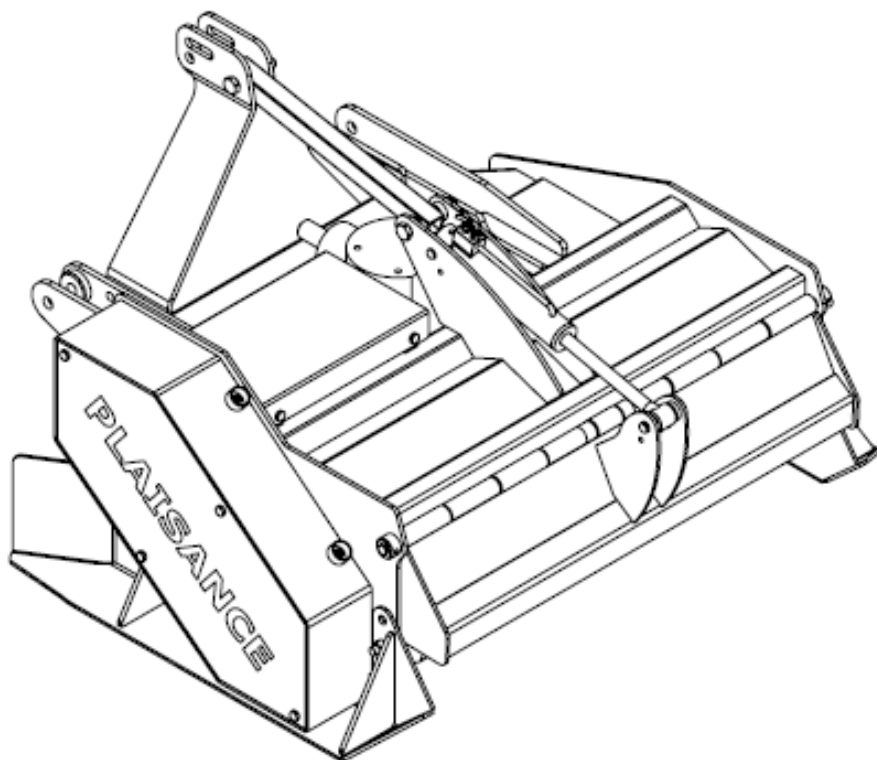

WEIGHT AND DIMENSIONS (kg and mm)

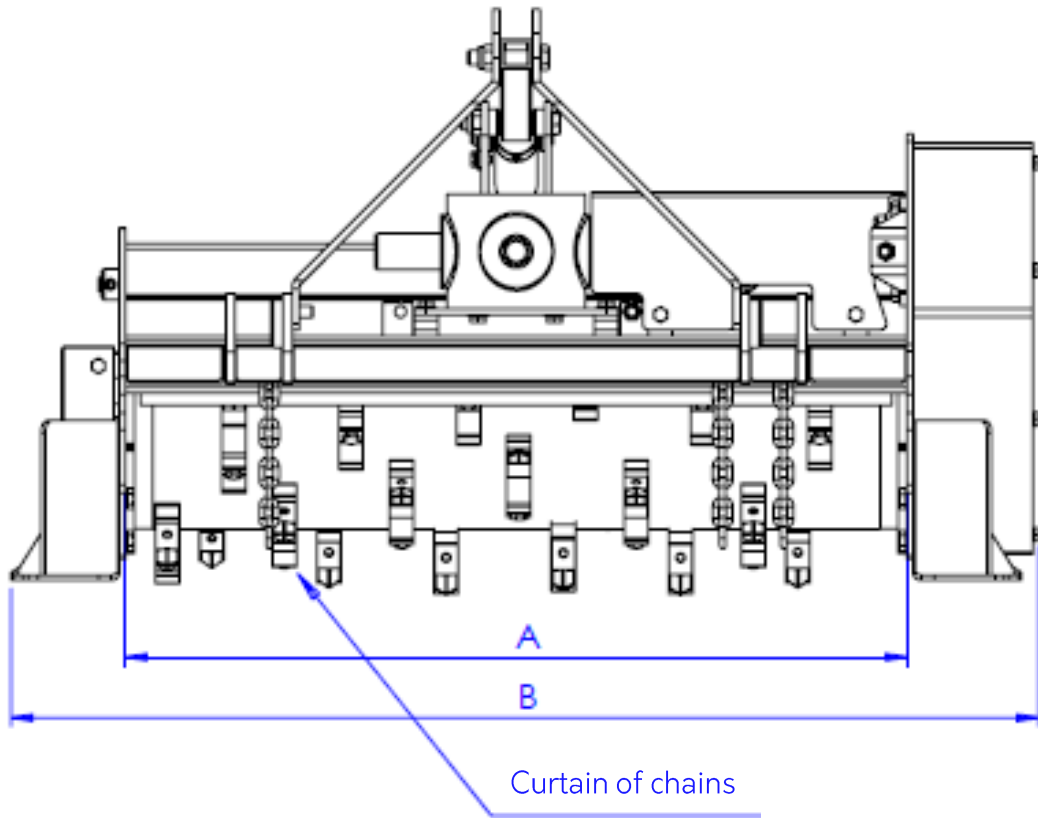

Working width (A)	Overall width (B)	Weight
1200 mm	1609 mm	900 kg
1300 mm	1709 mm	950 kg
1500 mm	1909 mm	1100 kg

Illustrations and dimensions are for indication only.
 PLAISANCE EQUIPEMENTS reserves the right to modify them without notice.
 This plan is the property of PLAISANCE EQUIPEMENTS and may not be reproduced or
 communicated without permission.
 All rights reserved

