



TECHNICAL DATASHEET

BF 702

CONTACT US:

1 Grande rue
54540 MONTIGNY, France
Tel: +33 3 83 42 15 79



WWW.PLAISANCE-EQUIPEMENTS.COM

BF 702

GENERAL INFORMATION

Rotor widths	2,2 m	2,5 m
Rotor diameter	650 mm	
Use	Forestry mulching	
Teeth	Simple carbide tips + side teeth	
Teeth position on the rotor	Fixed - Helical and V positions	
Engine power	300 to 600 hp	
Side belt transmission to rotor	2 polychain belts in carbon	
Curtain of chains	Anti-projection triple curtain of chains	
Hydraulic rake	With two cylinders (public works)	
Protection door	With two cylinders (public works)	
Frame	Strengthen - High tensile steel	
Rolling	Heavy duty roller bearings with double rows of rollers	
Rotor axis	Bolted shaft	
Skids	HARDOX 450® soles Adjustable in 3 positions : + 45 mm / 0 mm / - 45 mm	
Protections	Anti-wire cut in mass, bolted and interchangeable	
Gearbox	600 hp	
Hitch	3 rd and 4 th hydraulic point	

SIMPLE CARB TIP TEETH

HOLDERS

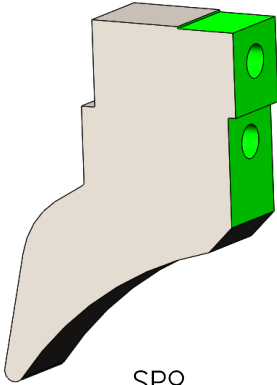

SP9

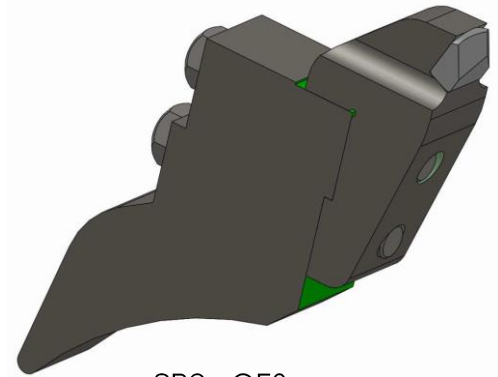

SP9+OF3

TEETH



Wood tool
 Simple carb tip

OF3
 98 to 112 teeth



Wood tool
 Simple carb tip

OF8
 98 to 112 teeth

SIDE TEETH



Side tool
 Double carb tip

OFL1
 2 side teeth



Side tool
 Quadruple carb tip

OFL2
 2 side teeth

Our side teeth are the same on the left and right.

PLAN AND DIMENSIONS

US version

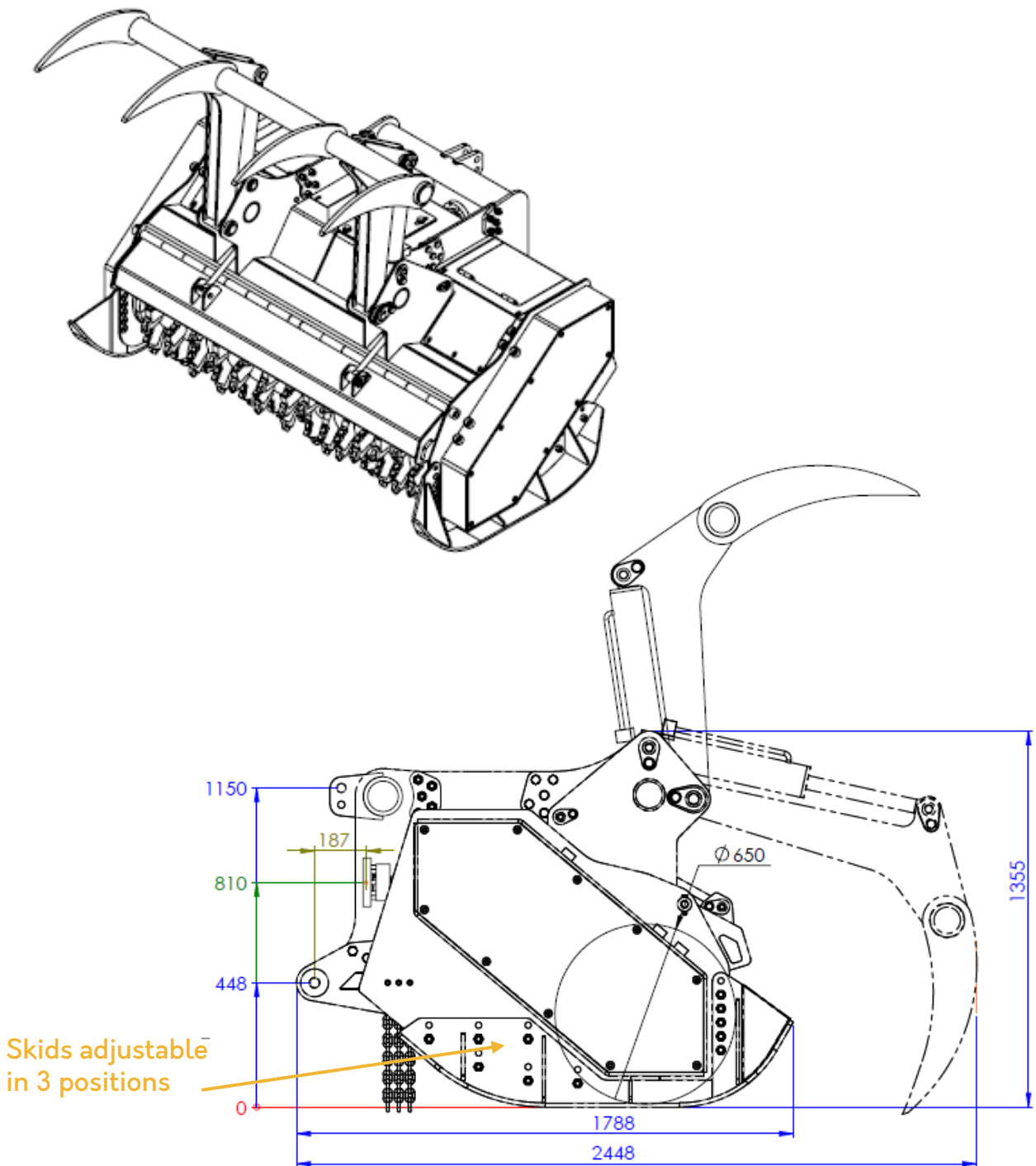

Illustrations and dimensions are for guidance only.
 PLAISANCE EQUIPEMENTS reserves the right to modify them without notice.
 This plan is the property of PLAISANCE EQUIPEMENTS and may not be reproduced or
 transmitted without permission.
 All rights reserved

RAKES AND DOOR



Rakes raised – Door closed



Rakes raised – Door opened



Rakes lowered – Door closed



Rakes lowered – Door opened

WEIGHT AND DIMENSIONS (kg and mm)

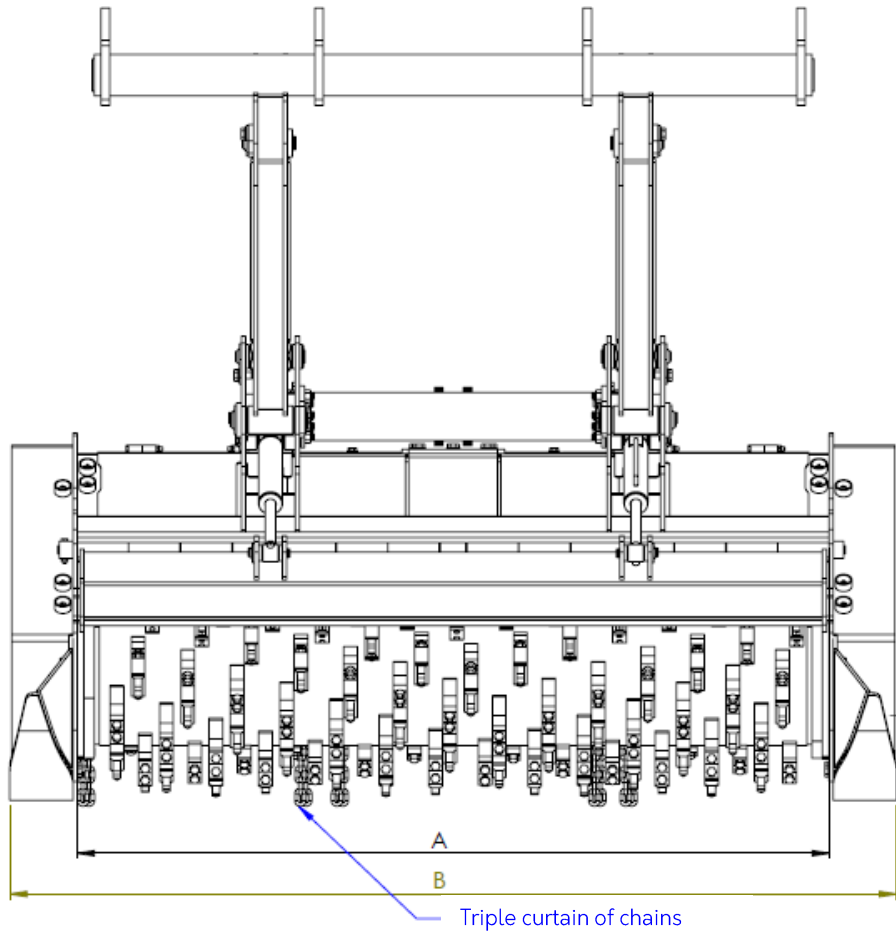

Working width (A)	Overall width (B)	Weight
2200 mm	2594 mm	3700 kg

Illustrations and dimensions are for indication only.
 PLAISANCE EQUIPEMENTS reserves the right to modify them without notice.
 This plan is the property of PLAISANCE EQUIPEMENTS and may not be reproduced or
 communicated without permission.
 All rights reserved

